



⚠ DANGER



Electrical Shock Hazard
 Only authorized technicians should perform diagnostic voltage measurements.
 After performing voltage measurements, disconnect power before servicing.
 Failure to follow these instructions can result in death or electrical shock.

⚠ WARNING



Electrical Shock Hazard
 Disconnect power before servicing.
 Replace all parts and panels before operating.
 Failure to do so can result in death or electrical shock.

Voltage Measurement Safety Information

When performing live voltage measurements, you must do the following:

- Verify the controls are in the off position so that the appliance does not start when energized.
- Allow enough space to perform the voltage measurements without obstructions.
- Keep other people a safe distance away from the appliance to prevent potential injury.
- Always use the proper testing equipment.
- After voltage measurements, always disconnect power before servicing.

ACTIVATING THE SERVICE DIAGNOSTIC MODES

1. Enter Diagnostics Mode by pressing CANCEL>CANCEL>START within 5 seconds.
2. Press the “up” arrow keypad to scroll through the diagnostics settings.

NOTES:

- Entering Diagnostics mode will cancel any active oven operation.
- Enter the Diagnostics mode only after the oven is cool.

ERROR CODES

Code	Description
No display	Control not operational
F1E0 F1E1 F1E2	Internal board failure A/D Error(s)
F2E1	Shorted keypad
F3E0	Oven sensor opened Oven sensor shorted Bake/Broil range over temperature Clean range over temperature
F5E0	Door and switches do not agree (Clean mode)
F5E1	Door latch not operating (Clean mode)
F6E1	Oven over temperature when heating
F9E0	Miswired house Miswired range

RESISTANCES

Component	Pinout	Resistance or Voltage
Door switch	P3-1 to P3-2	2 VDC with door open 0 VDC with door closed
Oven temperature sensor	P3-4 to P3-5	1000-1200 Ω at room temperature.
Oven light	P2-1 to WH (neutral) P1-3	0-40 Ω nominal
Bake element	P4-3 to P5-4	10-40 Ω nominal
Broil element	P5-1 to P5-4	10-40 Ω nominal
Thermo fuse	P5-1 to P5-4	240 VAC
Door latch motor	P3-3 to WH (neutral) P1-3	500-3000 Ω
Radiant element (single)	H1 to H2	240 VAC
Radiant element (dual)	H1A to H2	240 VAC
Coil element	H1 to H2	240 VAC

IMPORTANT: Electrostatic discharge may cause damage to machine control electronics. Refer to online Tech Manual for additional information.

Check for proper voltage by completing the following steps:

1. Disconnect the power or unplug the appliance.
2. Connect voltage measurement equipment to proper connectors.
3. Plug in appliance or reconnect power and confirm voltage reading.
4. Disconnect the power or unplug the appliance.

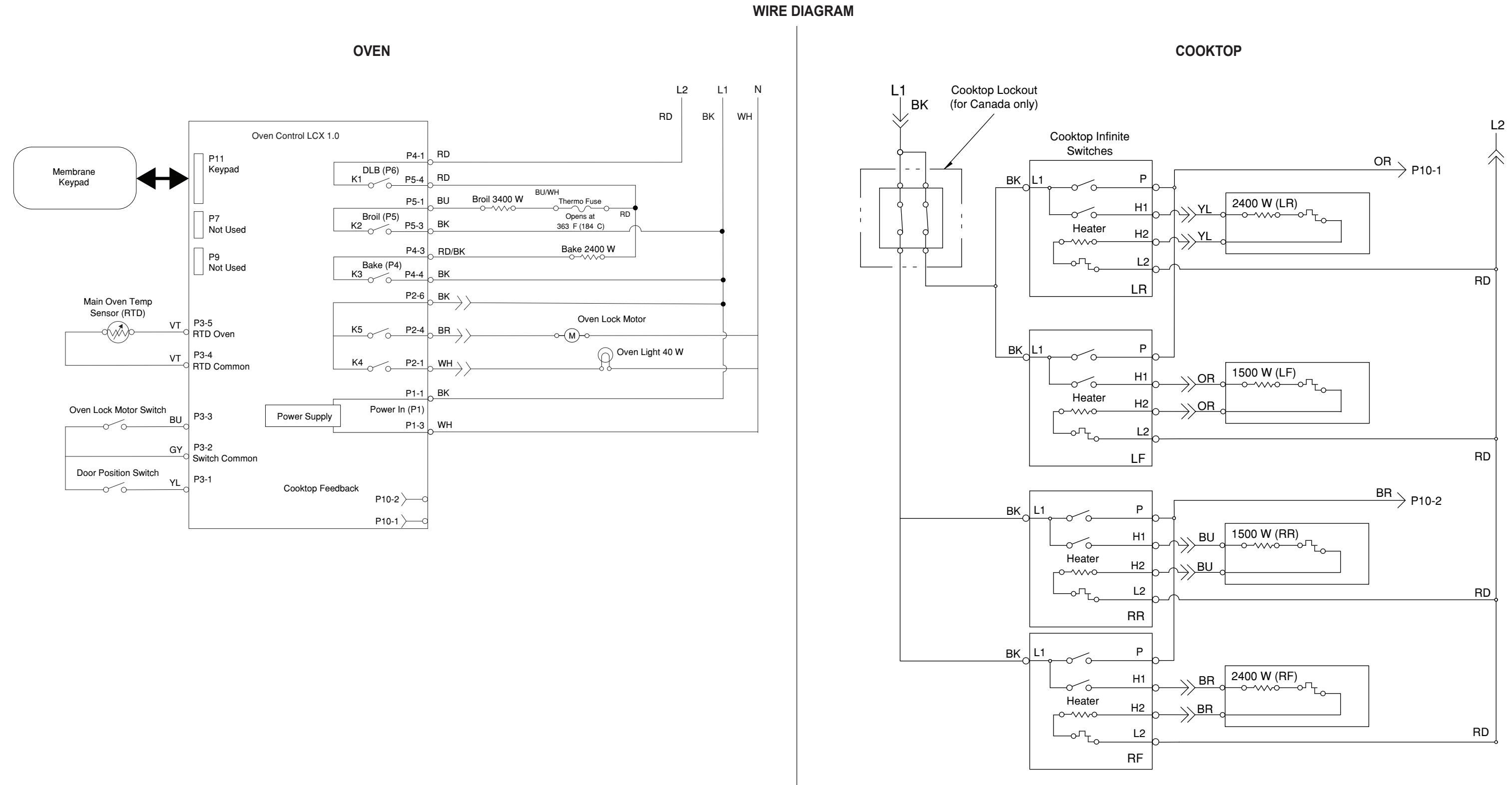

WIRE DIAGRAM

LEGEND

																		P1-2 = Connector P1, Pin 2	Multiple Functions / Circuitry Enclosed Within
--	--	--	--	--	--	--	--	--	--	--	--	--	--	--	--	--	--	----------------------------	--